

N-Channel Enhancement Mode Field Effect Transistor

Product Summary

- V_{DS} 20V
- I_D 4.3A
- $R_{DS(ON)}$ (at $V_{GS}=4.5V$) <27 mohm
- $R_{DS(ON)}$ (at $V_{GS}=2.5V$) <37 mohm

General Description

- Trench Power LV MOSFET technology
- High Power and current handling capability
- Marking : A2SHB

Applications

- PWM application
- Load switch

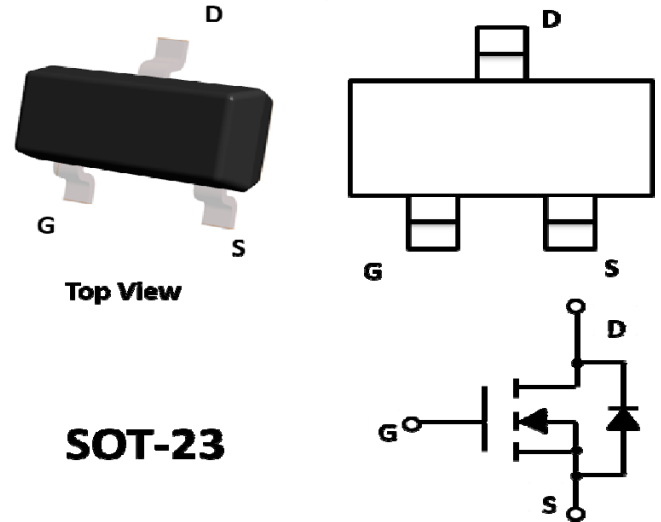

Absolute Maximum Ratings ($T_A=25^\circ\text{C}$ unless otherwise noted)

Parameter	Symbol	Limit	Unit
Drain-source Voltage	V_{DS}	20	V
Gate-source Voltage	V_{GS}	± 10	V
Drain Current	I_D	$T_A=25^\circ\text{C}$ @ Steady State	4.3
		$T_A=70^\circ\text{C}$ @ Steady State	3.5
Pulsed Drain Current ^A	I_{DM}	18	A
Total Power Dissipation @ $T_A=25^\circ\text{C}$	P_D	1.0	W
Thermal Resistance Junction-to-Ambient @ Steady State ^B	$R_{\theta JA}$	125	$^\circ\text{C}/\text{W}$
Junction and Storage Temperature Range	T_J, T_{STG}	-55~+150	$^\circ\text{C}$

Electrical Characteristics ($T_J=25^{\circ}\text{C}$ unless otherwise noted)

Parameter	Symbol	Conditions	Min	Typ	Max	Units
Static Parameter						
Drain-Source Breakdown Voltage	BV_{DSS}	$V_{GS}=0V, I_D=250\mu A$	20			V
Zero Gate Voltage Drain Current	I_{DSS}	$V_{DS}=20V, V_{GS}=0V, T_C=25^{\circ}\text{C}$			1	μA
Gate-Body Leakage Current	I_{GSS}	$V_{GS}=\pm 10V, V_{DS}=0V$			± 100	nA
Gate Threshold Voltage	$V_{GS(th)}$	$V_{DS}=V_{GS}, I_D=250\mu A$	0.55	0.85	1.25	V
Static Drain-Source On-Resistance	$R_{DS(on)}$	$V_{GS}=4.5V, I_D=4.3A$		21	27	m Ω
		$V_{GS}=2.5V, I_D=3.0A$		29	37	
Diode Forward Voltage	V_{SD}	$I_S=4.3A, V_{GS}=0V$			1.2	V
Maximum Body-Diode Continuous Current	I_S				4.3	A
Dynamic Parameters						
Input Capacitance	C_{iss}	$V_{DS}=10V, V_{GS}=0V, f=1\text{MHz}$		595		pF
Output Capacitance	C_{oss}			106		
Reverse Transfer Capacitance	C_{rss}			59		
Switching Parameters						
Total Gate Charge	Q_g	$V_{GS}=4.5V, V_{DS}=10V, I_D=4.3A$		6.6		nC
Gate Source Charge	Q_{gs}			0.9		
Gate Drain Charge	Q_{gd}			1.4		
Turn-on Delay Time	$t_{D(on)}$	$V_{GS}=4.5V, V_{DD}=10V, R_L=1.5\Omega, R_{GEN}=3\Omega$		13		ns
Turn-on Rise Time	t_r			54		
Turn-off Delay Time	$t_{D(off)}$			18		
Turn-off Fall Time	t_f			11		

 A. Pulse Test: Pulse Width $\leq 300\mu s$, Duty cycle $\leq 2\%$.

B. Device mounted on FR-4 PCB, 1 inch x 0.85 inch x 0.062 inch.

Typical Performance Characteristics

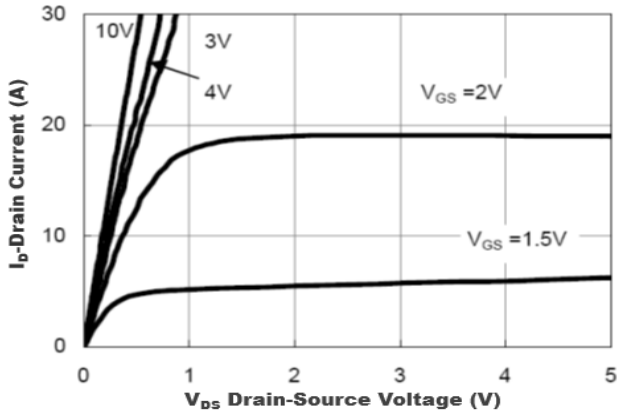

Figure1. Output Characteristics

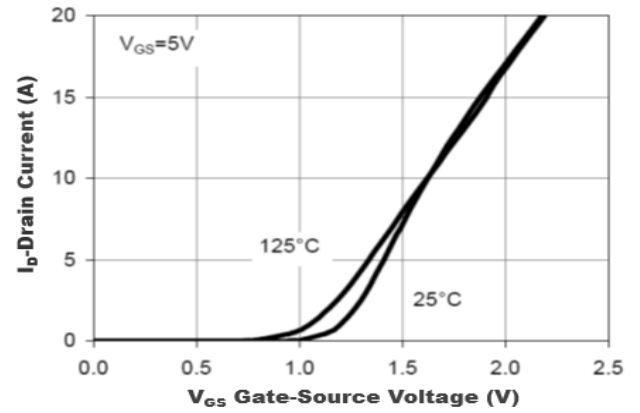

Figure2. Transfer Characteristics

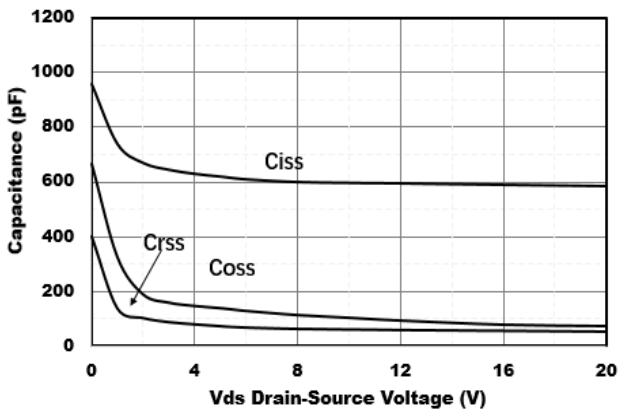

Figure3. Capacitance Characteristics

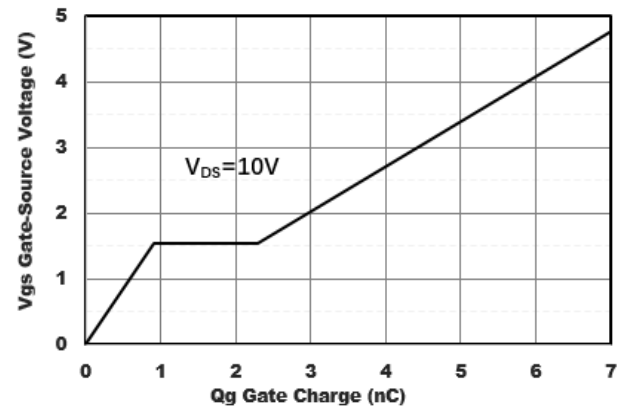

Figure4. Gate Charge

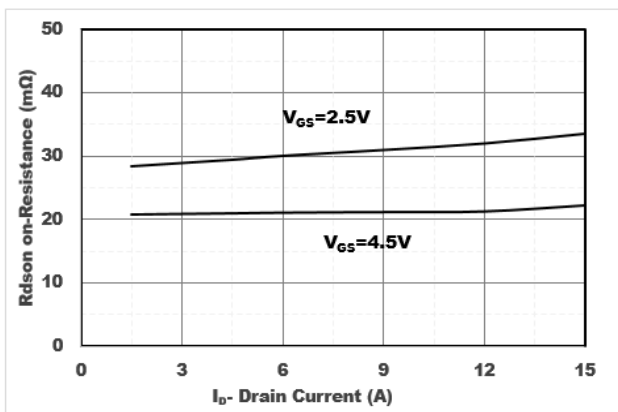

Figure5. Drain-Source on Resistance

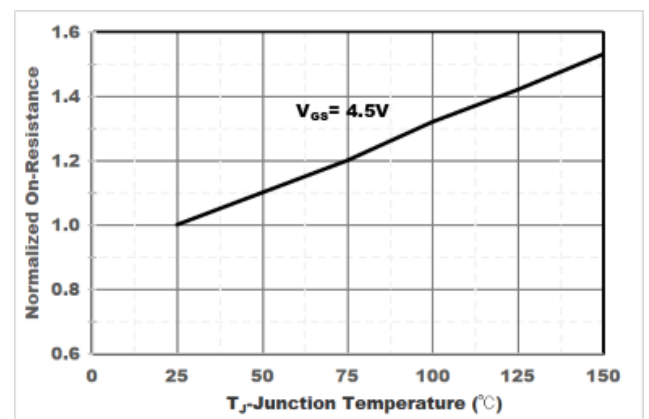

Figure6. Drain-Source on Resistance

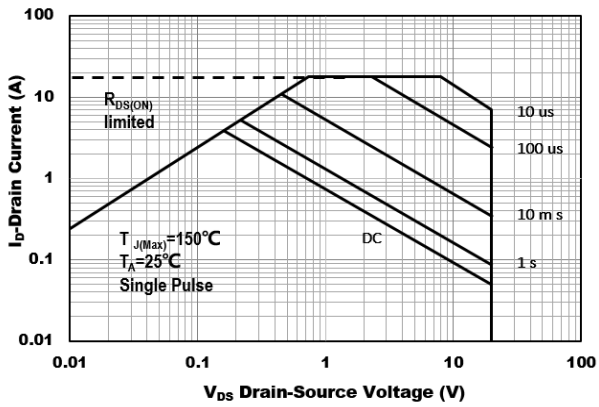

Figure7. Safe Operation Area

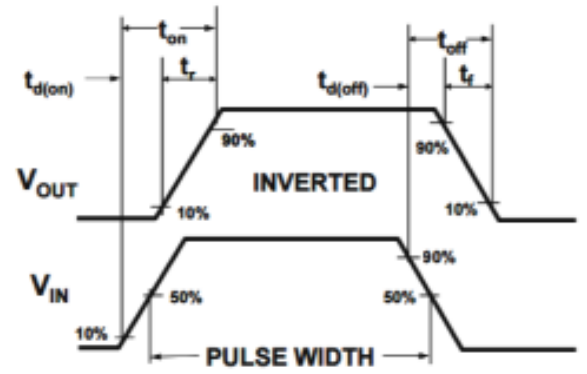

Figure8. Switching wave

Package Outline Dimensions (UNIT: mm)

SOT-23

